

VidPort SD/HD™

Single Channel HD/SD-SDI (SMPTE 292M, SMPTE 259M) Input or Output Card with Auto Standards Detection on Input. Input Card Converts to Output Card, and Vice-Versa, via Firmware. Includes Support for Linux® or Windows® OS. Full DirectShow® Support. Assumes Embedded Audio. HANC and VANC are Supported...

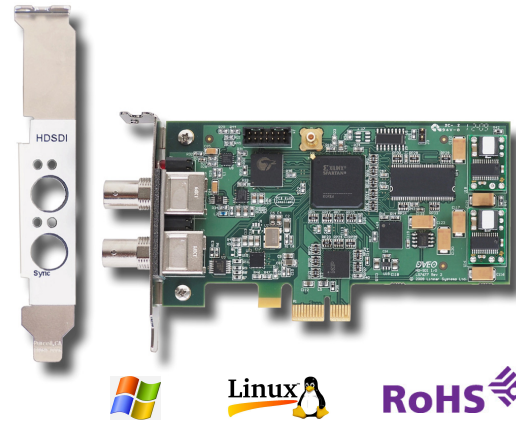

Features

- One software selectable HD/SD-SDI input or output channel on a low profile PCI Express card
- Input card can be converted to output card, or output card can be converted to input card
- Receives or transmits uncompressed HD/SD-SDI at bit rate up to 1.485 Gbps
- One lane (x1) low profile PCIe v1.1 card
- Uses highly efficient Bus Master Link List DMA for data transfer (saving CPU resources)
- Supported standards include 1080i, 720p, and 480i at 50 Hz, 60 Hz and 59.94 Hz rates, and 1080p at 23.98 Hz, 24 Hz, 25 Hz, 29.97 Hz, and 30 Hz
- Onboard DDR memory buffers data to account for latencies in data transactions on the PCIe bus
- Able to store four frames of data in either V210 or UYVY (also called Four CC code)
- Handles up to 8 channels of embedded audio
- Field Upgradeable Firmware
- RoHS compliant (2002/95/EC)
- Linux® and Windows® support, including Windows® 7 32 and 64 bit
- Receiver:
 - Automatic Standards detection
 - Automatic cable equalization of up to 200m of Belden 1694A cable at 1.485 Gbps
 - Input monitoring of CRC errors for both the Y and Cb/Cr lines of the input stream
- Transmitter:
 - Tri-level sync input for transmit rate synchronization

Applications

- HD-SDI Servers
- Post-Processing Stations
- Capture of HD video
- Storing HD video for editing applications
- Electronic news gathering (ENG)

Overview

HD-SDI (SMPTE 292M) is the primary interface worldwide for High Definition digital uncompressed video. Its bit rate is 1.485 Gbps. This standard evolved from SD-SDI, which supports standard resolution only and is defined by SMPTE as SMPTE 259M. This card supports both standards.

The **VidPort SD/HD™** is a single channel HD/SD-SDI card with a single lane PCI Express (PCIe) bus interface. It converts to a transmitter or receiver card with a firmware change.

The VidPort SD/HD receives or transmits one HD/SD-SDI stream and transfers the descrambled stream to/from the system memory via the PCIe bus. On board memory and a proprietary firmware design are used to buffer the inputs to account for system latency as the data flows to the PCIe bus.

When the card is in the receiver mode, the clock and data recovery block locks onto the incoming signal. Once locked, the card then deserializes, converts from NRZI to NRZ, descrambles and frames the stream into 10-bit words before writing the frame to on board memory. The card also supports de-interlacing in the hardware and can monitor the incoming stream for CRC errors. After each frame is written to the on board memory, the card then transfers the frame to the system over the PCIe bus.

The transmit stream can be synchronized with other HD/SD-SDI streams for switching, editing and overlays.

At this time, this card is targeted at OEMs who are building video servers, video encoders, and video capture systems. Later on we plan to introduce applications... and are interested in licensing yours if you have one!



Computer Modules, Inc.

11409 West Bernardo Court

San Diego, CA 92127

Tel: 858-613-1818 Fax: 858-613-1815

www.dveo.com

Specifications

Dimensions	
Width:	2.713 in. (6.89 cm)
Length:	4.721 in. (11.99 cm)
Thickness:	0.062 in. (0.157 cm)
Weight	3.1 oz. (88 g)
Connector	75 ohm BNC
Data Output	SMPTE 292M and SMPTE 259M uncompressed 4:2:2
Typical Power	1.5 A @ 3.3 V
Operating	0 to 55°C
Operating Humidity	To 90%, Non-condensing
Status LED Indicators	Rx (CD)
On board memory	32 MB
Bus Interface	PCIe x1 lane v1.1
Conformities	UL, CE, RoHS

Block Diagram

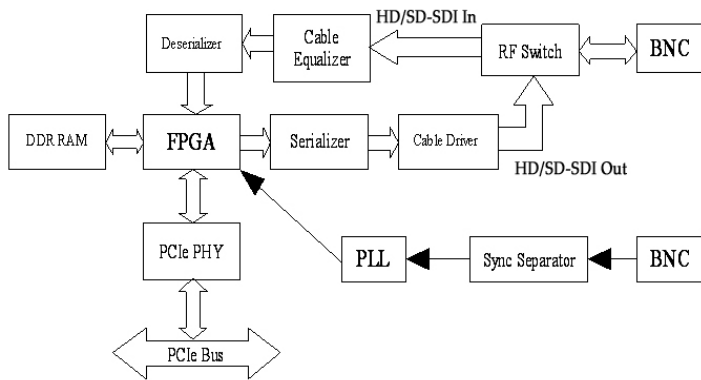

Recommended Motherboards

- Intel® I/5 and I/7 motherboards
- Dell® Xeon 54xx series chipset motherboards (Dell R710, PowerEdge 1950 III, and 2950 III)
- SuperMicro® motherboards

Ordering Information

VidPort SD/HD (Model 193)

© 2011 Computer Modules, Inc. DVEO and VidPort SD/HD are trademarks of Computer Modules, Inc. All other trademarks and registered trademarks are the properties of their respective owners. All rights reserved. Specifications are subject to change without notice.

Capabilities

Standards Supported – The receiver/transmitter supports the following HD/SD-SDI standards. (The receiver automatically detects and locks onto the HD/SD-SDI standards):

SMPTE 260M 1035i (60 Hz/59.94 Hz)	TX / RX
SMPTE 295M 1080i (50 Hz)	RX
SMPTE 274M 1080i (50 Hz)	TX / RX
SMPTE 274M 1080i (60 Hz/59.94 Hz)	TX / RX
SMPTE 274M 1080p (30 Hz/29.97 Hz)	TX / RX
SMPTE 274M 1080p (25 Hz)	TX / RX
SMPTE 274M 1080p (24 Hz/ 23.97 Hz)	TX / RX
SMPTE 274M 1080sF (24 Hz)	TX / RX
SMPTE 296M 720p (60 Hz/59.94 Hz)	TX / RX
SMPTE 296M 720p (50 Hz)	TX / RX
SMPTE 296M 720p (30 Hz/29.97 Hz)	TX / RX
SMPTE 296M 720p (25 Hz)	TX / RX
SMPTE 296M 720p (24 Hz/23.98 Hz)	TX / RX
SMPTE 125M 480i (59.94 Hz)	TX / RX
ITU-R BT.601 576i (50 Hz) – PAL	TX / RX

Indicator LEDs – Indicator LEDs are provided on the bracket to show receiver or transmitter operation. The LEDs flash to indicate when valid data is received or transmitted. When the channel is not in operation, the LED will be on if a carrier is detected.

Software Support

- Windows® 7 32 and 64 bit, Windows® XP, Windows® Server 2003, and Windows® Server 2008 driver, API, and sample applications support
- Linux® driver, API, and sample applications support
- DirectShow® SDK
 - o Source and Sink Filter Interface
 - o Interface to WME
 - o Support for GraphEdit
 - o Support for Direct X
- We have a DirectShow® filter we call the Sink Filter, which provides an interface to the Vidport SD/HD driver. The recommended input is a single program MPEG-2 transport stream at its input pin, although it will accept other formats. We also provide a sample application with source code that shows how to interface to the Sink Filter.



Computer Modules, Inc.

11409 West Bernardo Court

San Diego, CA 92127

Tel: 858-613-1818 Fax: 858-613-1815

www.dveo.com