

QuadPort H/i™

Quad Channel HD-SDI PCIe v1.1 Input Card with On Board Memory and Automatic Standards Detection For Real Time Video Capture – Total Aggregate Bit Rate of Almost 6 Gbps. Support for Windows® and Linux®. Includes DirectShow® SDK.

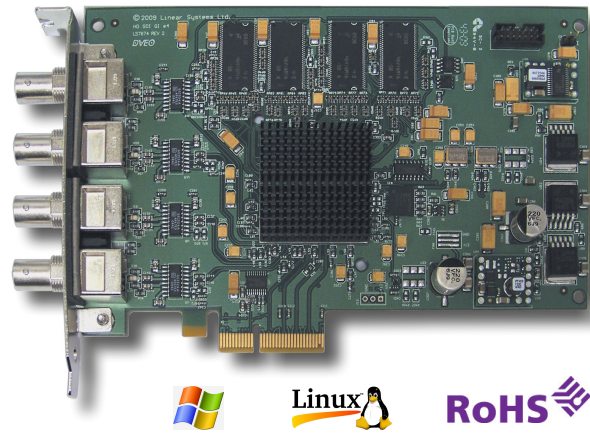

Features

- Four independent SMPTE 292M receiver channels on the same PCIe card
- Each input receives uncompressed HD-SDI at up to 1.485 Gbps
- Total aggregate bit rate of nearly 6 Gbps!
- NRZI to NRZ decoding
- Four Lane (x4) PCIe v1.1 card
- Supported standards include 1080i and 720p at 60 Hz and 59.94 Hz rates, 1080p at 30 Hz
- Automatic Cable Equalization of up to 200 m of Belden 1694A cable at 1.485 Gbps
- Onboard DDR memory buffers data to account for latencies in data transactions on the PCIe bus
- Uses highly efficient Bus Master Link List DMA for data transfer (saving CPU resources)
- Input monitoring of CRC errors for both the Y and Cb/Cr lines of the input stream
- Able to store four frames of data in either RAW, V210 Non-Deinterlaced, V210 Deinterlaced or UYVY (also called Four CC code) formats
- Embedded Audio extraction (up to 8 channels)
- Field Upgradeable Firmware
- RoHS compliant (2002/95/EC)
- Linux® and Windows® OS support, including Windows® 7 32 and 64 bit
- DirectShow® filter support
- Customized feature support available

Applications

- HD-SDI Ingest Servers
- Post-Processing Stations
- Encoding HD video
- Storing HD video for editing applications
- Electronic news gathering (ENG)

Overview

HD-SDI, also known as SMPTE 292M, is the worldwide standard format for uncompressed high definition serial digital video. The **QuadPort H/i™** is a four input channel HD-SDI card with an x4 lane PCI express (PCIe) bus interface. This card provides an efficient interface to today's high performance PC computers, giving increased flexibility for real-time HD capture.

The QuadPort H/i receives four independent HD-SDI streams and passes the descrambled stream to the system memory via the PCIe bus. Onboard oscillators allow users to receive either 1.485 Gbps or 1.4835 (1.485/1.001) Gbps input streams in order to support video formats defined for true 60 Hz rates as well as those defined for the 59.94 Hz rates commonly used in North America. Onboard memory and a proprietary firmware design are used to buffer the inputs to handle bus latencies as the data transfers over the PCIe bus.

The clock and data recovery block locks onto the incoming signal. Once locked, the card then deserializes, converts from NRZI to NRZ, descrambles and frames the stream into 10-bit words before writing the frame to onboard memory. The card also supports de-interlacing in hardware and can monitor the incoming stream for CRC errors. After each frame is written to the onboard memory, the QuadPort H/i card then transfers the frame to the system over the PCIe bus. In addition, embedded audio is extracted from the incoming stream and transferred to the host system over a separate DMA channel.

The QuadPort H/i features automatic standards detection. The firmware on the card does all the work in converting to the different HD-SDI formats to minimize the use of host CPU cycles.

The QuadPort H/i is an ideal solution for ingesting HD streams to a workstation for storage and editing.



Computer Modules, Inc.

11409 West Bernardo Court

San Diego, CA 92127

Tel: 858-613-1818 Fax: 858-613-1815

www.dveo.com

Specifications

Dimensions	
Width:	4.20 inches (10.67 cm)
Length:	6.6 inches (17.46 cm)
Thickness:	0.60 inches (1.53 cm)
Weight	7.1 oz (200 g)
Input Connectors	75 ohm BNC
Data Input	HD-SDI SMPTE 292M
Typical Power	15.45 W (0.96 A @ 3.3V; 1.02 A @ 12 V)
Operating Temperature	0 to 55° C
Operating Humidity	To 90%, Non-condensing
Status LED Indicators	Rx (CD)
Onboard memory	256 MB per channel
Bus Interface	PCIe x4 lane v1.1

Block Diagram

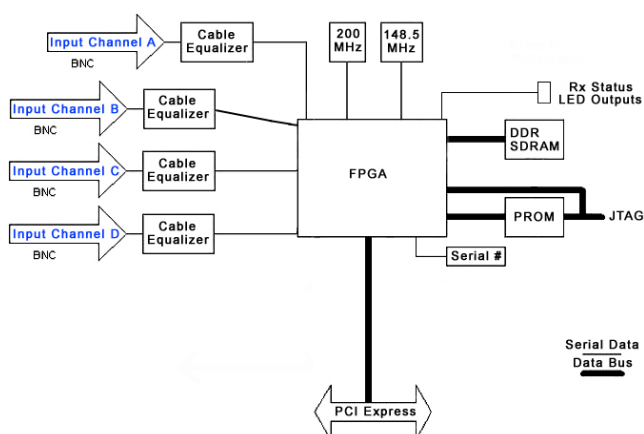

Tested Motherboards

- Intel® I/5 and I/7 motherboards
- Dell® Xeon 54xx series chipset motherboards (Dell R710, PowerEdge 1950 III, and 2950 III)
- SuperMicro® motherboards

Tested Servers

- Dell R710, PowerEdge 1950 III, and 2950 III

Ordering Information

QuadPort H/i (Model 182)

© 2012 Computer Modules, Inc. DVEO and QuadPort H/i are trademarks of Computer Modules, Inc. All other trademarks and registered trademarks are the properties of their respective owners. All rights reserved. Specifications are subject to change without notice.

Capabilities

Automatic Standards Detection – The receive channels will automatically detect and lock onto the following HD-SDI standards:

SMPTE 260M 1035i (60 Hz)
SMPTE 274M/295M 1080i (50 Hz)
SMPTE 274M 1080i (60 Hz/59.94 Hz)
SMPTE 274M 1080p (30 Hz/29.97 Hz)
SMPTE 274M 1080p (25 Hz)
SMPTE 274M 1080p (24 Hz/23.97 Hz)
SMPTE 274M 1080sF (24 Hz)
SMPTE 296M 720p (60 Hz/59.94 Hz)
SMPTE 296M 720p (50 Hz)
SMPTE 296M 720p (30 Hz/29.97 Hz)
SMPTE 296M 720p (25 Hz)
SMPTE 296M 720p (24 Hz/23.97 Hz)

Multiple frame rate support – Onboard oscillators allow receive inputs to lock to both 1.485 Gbps and 1.485/1.001 supported video formats. For example, the card supports both frame rates of 60 fields per second and also 59.94 fields per second as commonly used in North America.

Indicator LEDs – Indicator LEDs are provided on the bracket to show receiver operation (one LED per channel). The LED will flash to indicate when valid data is received on that channel. When the channel is not in operation, the LED will be on if a carrier is detected.

Software Support

- Windows® 7 32 and 64 bit, XP, Vista, Server 2003 and 2008, Master driver and API support
- Linux® driver and API support
- DirectShow® SDK
 - Source Filter Interface
 - Interface to WME
 - Support for GraphEdit
 - Support for Direct X

DVEO
Broadcast Division
Computer Modules, Inc.
11409 West Bernardo Court
San Diego, CA 92127
Tel: 858-613-1818 Fax: 858-613-1815
www.dveo.com