

IRiDium™ DVB-T

Versatile Standard Definition Integrated Receiver Decoder with DVB-T and DVB-ASI Input. Features DVB-ASI, SDI, YPbPr, and CVBS Outputs. Decodes Standard MPEG-2 Streams at 1 to 12 Mbps. Full Setup and Configuration via Web-based Management or LCD Front Panel. Supports PAL, NTSC, and SECAM.



Features

- Inputs:
 - DVB-T
 - DVB-ASI
- Outputs:
 - Two mirrored DVB-ASI outputs
 - Two mirrored SDI outputs
 - YPbPr
 - CVBS (Composite Video)
- Two Common Interface (CI) slots for descrambling most common CA systems
- Compatible with multi-decrypt CI modules
- Automatic PMT updates after program filtering
- VBI teletext, EBU subtitle and DVB subtitle processing
- Balance audio (XLR) output
- Management via front panel or Ethernet port
- Compatible with all SMiT brand CAM cards
- Software upgradeable via RS232 port or NMS
- Supports PAL, NTSC, and SECAM
- DVB-S/DVB-S2 version also available

Applications

- DVB-T receiver
- MPEG-2 Transport Stream Decoder
- Signal monitoring
- Content repurposing
- General head-end decoder

Overview

An IRD is an Integrated Receiver Decoder and is usually used by professionals as both an RF tuner and MPEG decoder in Cable Head Ends to receive and decode signals from content partners anywhere on earth. The IRiDium DVB-T is DVEO's cost effective professional IRD and is our solution for cable, business or private television networks. The IRiDium DVB-T is fully DVB standard compliant and naturally is equipped with a DVB-T demodulator, an MPEG-2 decoder, and single ASI input. Its numerous output interfaces include ASI, SDI, YPbPr, CVBS, and XLR audio, to meet many different system requirements.

The one RU, rack mountable, IRiDium DVB-T also has two common interface slots which can decode multiple scrambled channels.

The system can be operated with front panel controls or web-based management software. With multiple input and output, the IRiDium DVB-T can be used in many different settings – including traditional head-end networks and downlinks.



Computer Modules, Inc.

11409 West Bernardo Court
San Diego, CA 92127

Tel: 858-613-1818 Fax: 858-613-1815

www.dveo.com

IRiDium™ DVB-T

Rear View

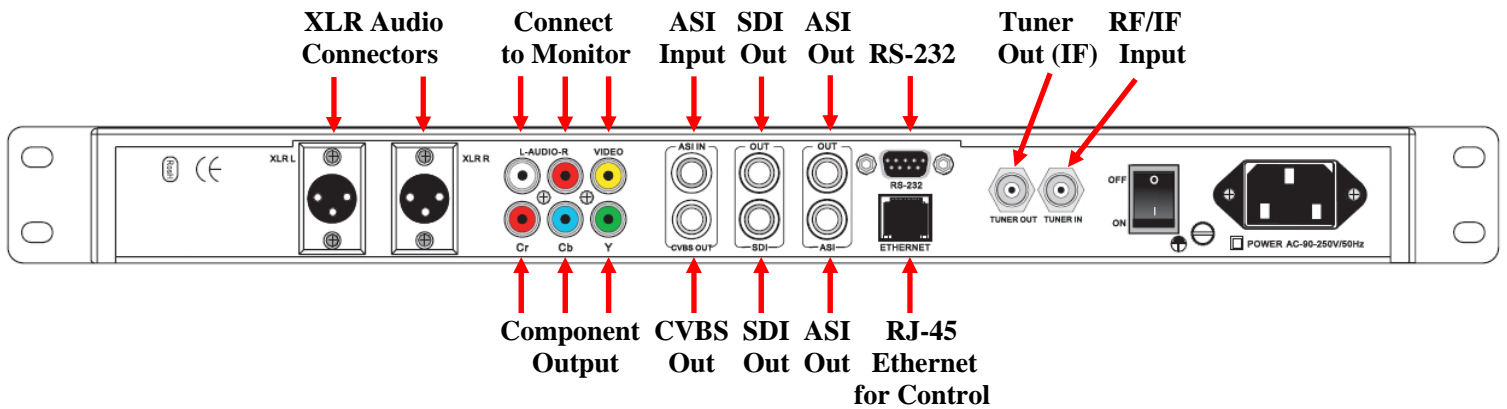

Specifications

Inputs

Inputs:	DVB-T, DVB-ASI
Loop-through:	Single L-Band RF input with LNB control and loop-through output
Connectors:	F-type, 75 ohm BNC 75 ohm RJ45 connector for Ethernet control
RF Input Level:	-65 ~ -25 dBm
Frequency Range:	ASI: 950 ~ 2150 MHz DVB-T: 48 ~ 858 MHz
MPEG-2 TS Input Bit Rate:	Up to 12 Mbps

Outputs

Outputs:	DVB-ASI, SDI, YPbPr and CVBS
Video Decode:	MPEG-II ISO/IEC 13818-1
Video Resolution:	720 × 576
Video Formats:	PAL/NTSC/SECAM
Connectors:	BNC 75 ohm
Loop-through:	F-type LNB RF loop-through output
TS Output Bit Rate:	1 to 72 Mbps
TS Format:	Single/Multiple programs
Audio:	Balance Audio (XLR) output SDI Output – Digital audio embedded
Audio Decoding:	MPEG-1 Layer I and II
Audio Modes:	Dual channel, Stereo, XLR, Mono

Control & Monitoring

Local:	Front panel operation LCD display
Remote:	Remote control via Ethernet port Software upgrades via RS232 port or NMS

Physical & Power

Power:	Input Voltage: AC 90V ~ 240V, 50/60 Hz Power Consumption: 20W (max)
Temperature:	0 to 40° C (32 to 104° F)
Dimensions:	1 RU 19 inch rack 19" (W) x 10.8" (D) x 1.7" (H) 484 (W) mm x 274 mm (D) x 44 mm (H)
Weight:	3.7 Kg (8.157 lbs.)
Conformities:	CE, RoHS

Application Example

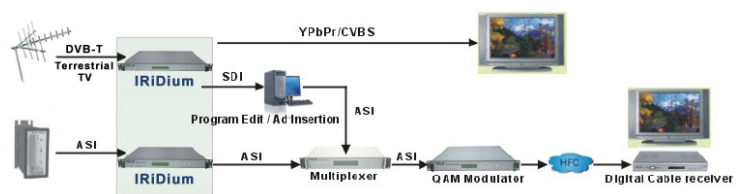

Ordering Info

IRiDium DVB-T
Also available: IRiDium S-S2